

MDPi Series

True-Flat Healthcare Display
with color calibration
User's Manual

Copyright

This publication contains information that is protected by copyright. No part of it may be reproduced in any form or by any means or used to make any transformation/adaptation without the prior written permission from the copyright holders.

This publication is provided for informational purposes only. The manufacturer makes no representations or warranties with respect to the contents or use of this manual and specifically disclaims any express or implied warranties of merchantability or fitness for any particular purpose. The user will assume the entire risk of the use or the results of the use of this document. Further, the manufacturer reserves the right to revise this publication and make changes to its contents at any time, without obligation to notify any person or entity of such revisions or changes.

Changes after the publication's first release will be based on the product's revision. The website will always provide the most updated information.

© 2020. All Rights Reserved.

Trademarks

Product names or trademarks appearing in this manual are for identification purpose only and are the properties of the respective owners.

Notice:

1. The changes or modifications not expressly approved by the party responsible for compliance could void the user's authority to operate the equipment.
2. Shielded interface cables must be used in order to comply with the emission limits.

About this Manual

This manual can be downloaded from the website. The manual is subject to change and update without notice, and may be based on editions that do not resemble your actual products. Please visit our website or contact our sales representatives for the latest editions.

Warranty

1. Warranty does not cover damages or failures that arised from misuse of the product, inability to use the product, unauthorized replacement or alteration of components and product specifications.
2. The warranty is void if the product has been subjected to physical abuse, improper installation, modification, accidents or unauthorized repair of the product.
3. Unless otherwise instructed in this user's manual, the user may not, under any circumstances, attempt to perform service, adjustments or repairs on the product, whether in or out of warranty. It must be returned to the purchase point, factory or authorized service agency for all such work.
4. We will not be liable for any indirect, special, incidental

Table of Contents

Copyright.....	2
Trademarks.....	2
Notice:.....	2
About this Manual.....	2
Warranty.....	2
Chapter 1 - Introduction.....	4
1.1 Monitor description.....	4
1.2 Box of contents.....	4
1.3 Product overview.....	4
1.4 Key Features.....	7
1.5 Outline Dimension.....	8
Chapter 2 - Important information.....	9
2.1 Safety Information.....	9
2.2 Environmental Information.....	10
2.3 Regulatory Information.....	11
2.4 Equipment Symbols.....	11
Chapter 3 - Cleaning the display.....	13
3.1 Cleaning instructions.....	13
3.2 EMC notice.....	13
Chapter 4 - Monitor Installation.....	15
4.1 Cleaning instructions.....	15
4.2 Stand removal & VESA mount installation.....	16
Chapter 5 - Daily operation.....	18
5.1 Main power switch.....	18
5.2 Power/Status indication.....	18
Chapter 6 - OSD menu operation.....	19
6.1 On-Screen Display.....	19
6.2 Menu Descriptions.....	19
6.3 OSD Structure.....	19
6.4 Main Menu.....	20
6.4.1 Exit.....	20
6.4.2 Auto Setup (Only Support Analog).....	20
6.4.3 Brightness.....	21
6.4.4 Contrast.....	21
6.4.5 Display (Only Support Analog).....	21
6.4.6 Color Mode.....	22
6.4.7 Clock/Phase (Only support Analog).....	23
6.4.8 Audio.....	23
6.4.9 Management.....	24
6.4.9.1 Scaling.....	25
6.4.9.2 OSD Display.....	25
6.4.9.3 Scaling.....	26
6.4.9.4 Source.....	26
6.4.9.5 Power Key Lock.....	27
6.4.9.6 Recall.....	27
6.4.10 Operating Hours.....	27
6.5 Supported Video Modes.....	28

Chapter 1 - Introduction

► 1.1 Monitor description

The equipment is applied for healthcare that is intended for general use in hospital environment for data collection and display for reference. It shall not be used with life support system or for medical diagnosis.

Type of equipment: Portable (on a table) Intended location: Medical environment
Intended User Profile

Intended User Profile

Age:	Adult (Age above 21)
Gender:	Can be use by all genders
Linguistic/ Cultural Background:	At least English
Education/ Professional Competence:	General level of education
Intended User Group:	Hospital staff
Knowledge Base:	User should possess basic medical knowledge

► 1.2 Box of contents

- 21.5"/23.8"/27" LCD Touch Screen Monitor
- AC Power Cord
- VGA Cable
- DVI or HDMI Cable
- USB Cable (for touch version)
- Power Adapter (Delta 24V)

(Optional)

- Audio Cable
- RS232 Cable
- DP Cable

The main body and accessories in the package may not come similar to the information listed above. This may differ in accordance with the sales region or models in which it was sold. For more information about the standard package in your region, please contact your dealer or sales representative.

► 1.3 Product overview

Front View

The image below shows the front view of the display.



1. P-CAP touch (for touch version) / AG/AR/CLEAR cover glass
2. Bezel
3. LED

Side View

The image below shows the control keys located in the right bottom corner of the display.

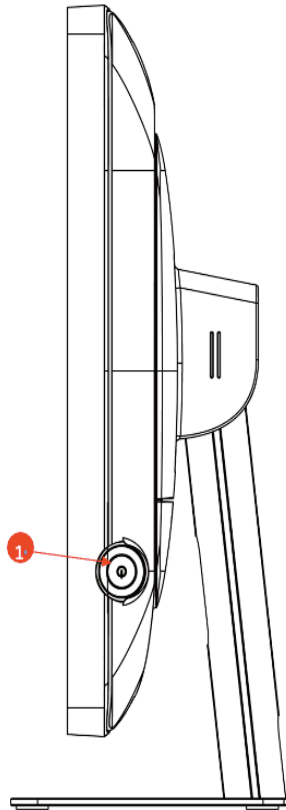

e 1-2 Control Keys

1. Menu / Enter key / Scrolling key

Rear View

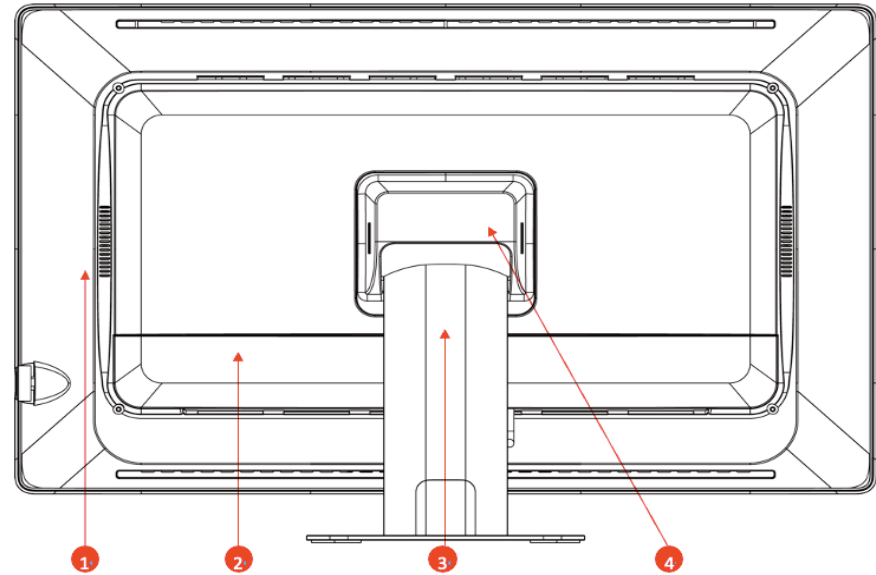
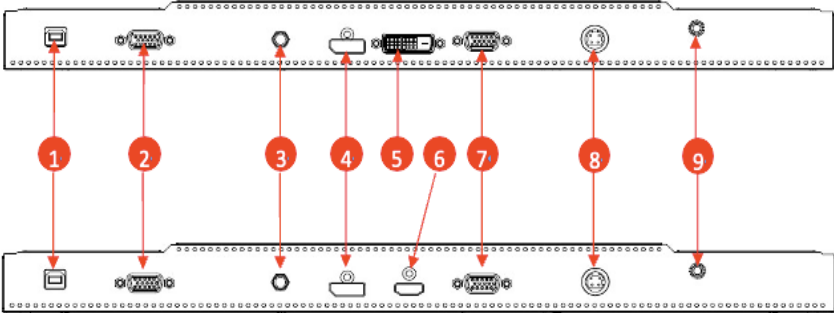



Image 1-3 Rear view

1. Rear cover
2. IO cover
3. Monitor stand
4. Hinge cover

Available Connections



- 1. USB
- 2. RS232
- 3. Audio
- 4. Display Port
- 5. DVI
- 6. HDMI (RGD model)
- 7. VGA
- 8. POWER
- 9. 

► 1.4 Key Features

Model		MDPi215	MDPi238	MDPi270
Display	Display	21.5" TFT LCD	23.8" TFT LCD	27" TFT LCD
	Max. Resolution	1920 x 1080	1920 x 1080	1920 x 1080
	Luminance	350 nits	250 nits	300 nits
	Contrast	1000:1	1000:1	3000:1
	View Angle	178(H) / 178(V)	178(H) / 178(V)	178(H) / 178(V)
	Color Depth	8 bits	6 bits + FRC	8 bits
	Display Colors	16.7M	16.7M	16.7M
	Response Time (ms)	22 (On/Off)	14 (GtG)	12 (On/Off)
Touch Screen	Backlight MTBF	50,000 hrs (Min.)	30,000 hrs (Min.)	30,000 hrs (Min.)
	Type	Projected Capacitive	Projected Capacitive	Projected Capacitive
	Touch Point	10	10	10
	Glass Coating	AG	AG	AG
Systems	Interface	Combo(USB/RS232)	Combo(USB/RS232)	Combo(USB/RS232)
	Color Temperature	Neutral/Warm/Cool/User	Neutral/Warm/Cool/User	Neutral/Warm/Cool/User
	Gamma Selection	Neutral/2.2/DICOM	Neutral/2.2/DICOM	Neutral/2.2/DICOM
	Gamma LUT (bits)	10	10	10
	OSD Languages	English/French/German/Italian/Spanish/Japanese	English/French/German/Italian/Spanish/Japanese	English/French/German/Italian/Spanish/Japanese
	Speaker	2 x 2W Speaker	2 x 2W Speaker	2 x 2W Speaker
I/O Interface	VGA	1 x VGA	1 x VGA	1 x VGA
	DP	1 x DP1.2	1 x DP1.2	1 x DP1.2
	HDMI	1 x HDMI 1.4	1 x HDMI 1.4	1 x HDMI 1.4
	Audio	1 x Line-in	1 x Line-in	1 x Line-in
	Power input	1 x DC IN	1 x DC IN	1 x DC IN
	Power requirements	AC Input	External power adapter,100 ~ 250V	External power adapter,100 ~ 250V
Power Consumption		40W (Max)	40W (Max)	40W (Max)
Mechanical	Chassis Material	Plastic (PC+ABS)	Plastic (PC+ABS)	Plastic (PC+ABS)
	Color	White	White	White
	Dimension (W)(H)(D)	"537 (W) x 387 (H) x 175 (D) mm (with Stand) 537 (W) x 339 (H) x 69 (D) mm (w/o Stand)"	"581 (W) x 400 (H) x 175 (D) mm (with Stand) 581 (W) x 360 (H) x 69 (D) mm (w/o Stand)"	"651 (W) x 441 (H) x 175 (D) mm (with Stand) 651 (W) x 402 (H) x 69 (D) mm (w/o Stand)"
	Weight	"8.2 (with Stand) 6.5 (w/o Stand)"	"9.5 (with Stand) 7.7 (w/o Stand)"	"10.3 (with Stand) 8.4 (w/o Stand)"
	Mounting	100 x 100 mm VESA mount	100 x 100 mm VESA mount	100 x 100 mm VESA mount
	Operating Temperature	0°C ~ 40°C	0°C ~ 40°C	0°C ~ 40°C
	Storage Temperature	-20°C ~ 60°C	-20°C ~ 60°C	-20°C ~ 60°C
	Operating Humidity	30% to 75% non-condensing	30% to 75% non-condensing	30% to 75% non-condensing
Others	OSD	"RotaryKnob buttons on the side edge Power On/Off, Menu"	"RotaryKnob buttons on the side edge Power On/Off, Menu"	"RotaryKnob buttons on the side edge Power On/Off, Menu"
Certifications	EMC / Safety	cTUVus(60601 Ed3.1),CE(EN 60601-1, EN60601-1-2,)FCC-class B	cTUVus(60601 Ed3.1),CE(EN 60601-1, EN60601-1-2,)FCC-class B	cTUVus(60601 Ed3.1),CE(EN 60601-1, EN60601-1-2,)FCC-class B
Protection	IP level	IP65 Front Panel	IP65 Front Panel	IP65 Front Panel
Accessory	Packing List	"Audio Cable	"Audio Cable	"Audio Cable
		DP Cable	DP Cable	DP Cable
		HDMI Cable	HDMI Cable	HDMI Cable
		VGA Cable	VGA Cable	VGA Cable
		USB 2.0 Cable	USB 2.0 Cable	USB 2.0 Cable
		Power Adapter"	Power Adapter"	Power Adapter"

► 1.5 Outline Dimension

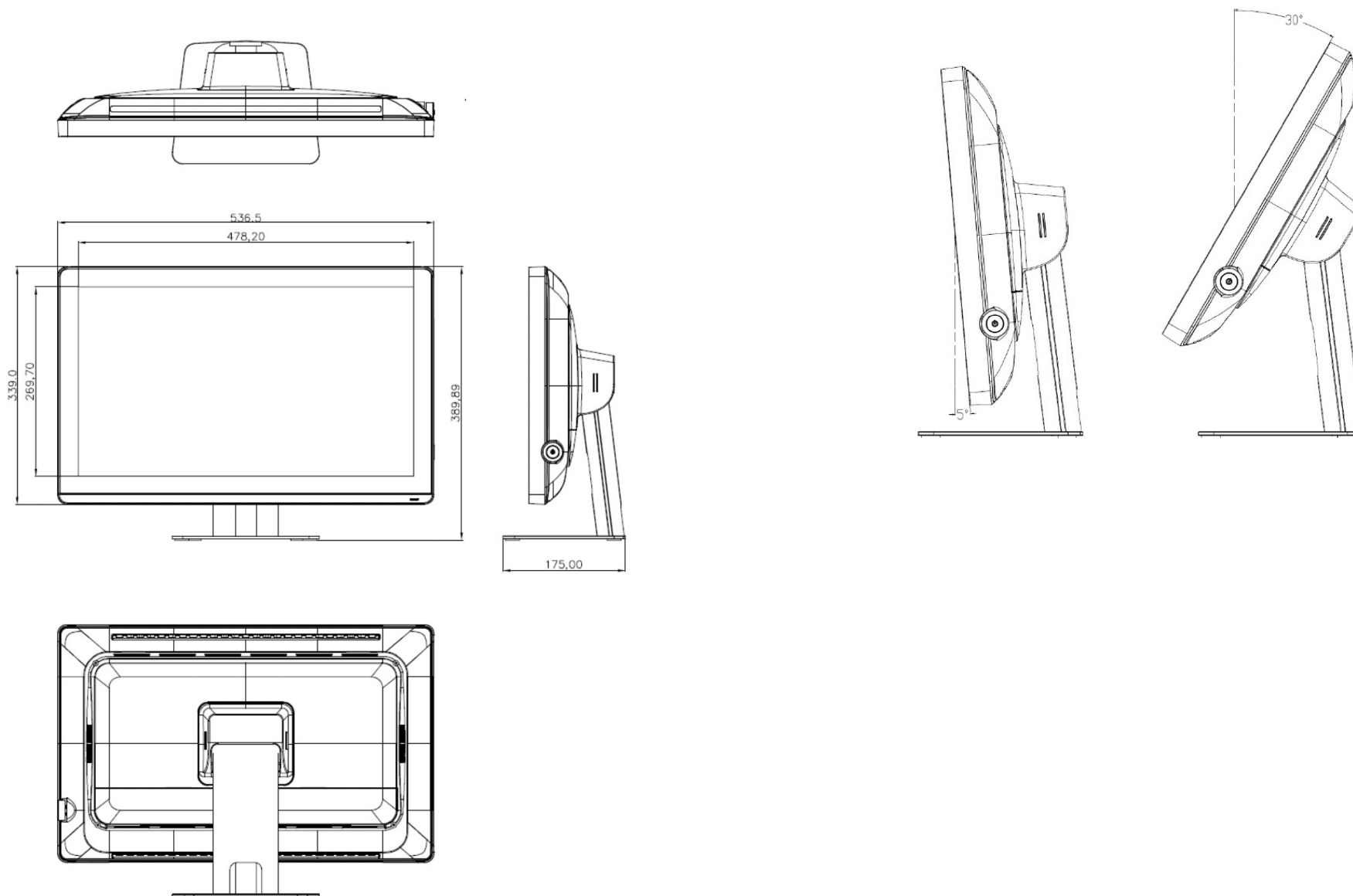

Chapter 2 - Important information

► 2.1 Safety Information

General recommendations

Read the safety and operating instructions before operating the device. Save the safety and operating instructions for future reference.

Adhere to all warnings on the device and in the operating instructions manual. Follow all instructions for operation and use.

Electrical Shock or Fire Hazard

To prevent an electrical shock or fire hazard, do not remove the cover. No serviceable parts are inside. Refer servicing to qualified personnel. Do not expose this apparatus to rain or moisture.

Modifications to the unit:

Do not modify this equipment without authorization of the manufacturer.

Degree of safety (flammable anesthetic mixture):

Equipment is not suitable for use in the presence of a flammable anesthetic mixture of air, oxygen, or nitrous oxide.

Non-patient care equipment

- Equipment primarily for use in a health care facility. It is intended for use when contact with a patient is unlikely (no applied part).
- The equipment may not be used with life support equipment.
- The user should not touch the equipment, nor its signal input ports (SIP)/signal output ports (SOP) and the patient at the same time.

Mission critical applications

We strongly recommend for there to be a replacement monitor immediately available in mission critical applications.

Power connection – Equipment with internal power supply

- This equipment must be grounded.
- Power requirements: The equipment must be powered by the DC mains voltage.
- The equipment is intended for continuous operation.

Power cords:

- Do not overload wall outlets and extension cords as this may result in fire or electric shock.
- Main leads protection (U.S.: Power cord): Power cords should be routed so that they are not walked upon or pinched by items placed upon or against them. Pay particular attention to cords at plugs and receptacles.
- The power supply cord should be replaced by the designated operator only at all time.
- Use a power cord that matches the voltage of the power outlet, which should be approved and in compliance with the safety standard of your particular country.
- Avoid placing the monitor near places that is hard to reach or difficult to disconnect the power supply cord.
- “WARNING: To avoid risk of electric shock, this equipment must only be connected to a supply mains with protective ground”
- “AVERTISSEMENT” : Pour éviter le risque de choc électrique, cet équipement doit être uniquement raccordé à un réseau d'alimentation avec protection par mise à la terre.

Grounding reliability

Grounding reliability can only be achieved when the equipment is connected to an equivalent receptacle.

Liquids and moisture

Never expose the monitor to liquids or moisture.

Never use the monitor near water - e.g. near a bathtub, washbasin, swimming pool, kitchen sink, laundry tub or in a wet basement.

Ventilation

Do not cover or block any ventilation openings in the cover of the set. When installing the device in a cupboard or another closed location, heed the necessary space between the set and the sides of the cupboard.

Installation

Place the device on a flat, solid, and stable surface that can support the weight of at least 3 devices. If you use an unstable cart or stand, the device may fall, causing serious injury to a child or adult, and serious damage to the device.

Accessory equipment connected to the analog and digital interfaces must be in compliance with the respective nationally harmonized IEC standards (i.e. IEC 60601-1 for medical equipment.) Furthermore all configurations shall comply with the system standard in IEC 60601-1. Anyone who connects additional equipment to the signal input part or signal output part is configuring a medical system, and is therefore, responsible that the system complies with the requirements of the system standard IEC 60601-1. The unit is for exclusive interconnection with IEC 60601-1 certified equipment in the patient environment and IEC 60XXX certified equipment outside of the patient environment.

This apparatus conforms to:

EN 60601-1:2006+A11:2011+A1:2013+A12:2014
IEC 60601-1: 2005 + CORR. 1 (2006) + CORR. 2 (2007) + AM1(2012) ANSI/AAMI ES60601-1:2005+A2(R2012)+A1
CAN/CSA-C22.2 No. 60601-1:14
EN 60601-1-2 (2015)
IEC 60601-1-2 (2014)
FCC CFR 47 Part 15 Subpart B (Level B) RoHS (2011/65/EU & 2015/863/EU)

► 2.2 Environmental Information

Disposal Information

Waste Electrical and Electronic Equipment



This symbol on the product indicates that under the European Directive 2012/19/EU, governing waste from electrical and electronic equipment, this product must not be disposed of with other municipal waste. Please dispose of your waste equipment by handing it over to a designated collection point for the recycling of waste electrical and electronic equipment. To prevent possible harm to the environment or human health from uncontrolled waste disposal, please separate these items from other types of waste and recycle them responsibly to promote the sustainable reuse of material resources. For more information about recycling of this product, please contact your local city office or your municipal waste disposal service.

► 2.3 Regulatory Information

Indications for use

The monitor (21.5"/23.8"/27" Touch Screen LCD Monitor) is applied for healthcare that is intended for general use in hospital environment for data collection and display for reference.

FCC class B

This device complies with Part 15 of the FCC Rules. Operation is subject to the following two conditions:

(1) This device may not cause harmful interference, and (2) this device must accept any interference received, including interference that may cause undesired operation.

This device has been tested and found to comply with the limits for a Class B digital device, pursuant to Part 15 of the FCC Rules. These limits are designed to provide reasonable protection against harmful interference in a residential installation. This device generates uses and can radiate radio frequency energy and, if not installed and used in accordance with the instructions, may cause harmful interference to radio communications. However, there is no guarantee that interference will not occur in a particular installation. If this device does cause harmful interference to radio or television reception, which can be determined by turning the device off and on, the user is encouraged to try to correct the interference by one or more of the following measures:

- Reorient or relocate the receiving antenna.
- Increase the separation between the device and receiver.
- Connect the device to an outlet on a circuit different from that to which the receiver is connected.
- Consult the dealer or an experienced radio/TV technician for help.













Changes or modifications not expressly approved by the party responsible for compliance could void the user's authority to operate the equipment.









Canadian notice

This ISM device complies with Canadian ICES-003.
Cet appareil ISM est conforme à la norme NMB-001 du Canada.

► 2.4 Equipment Symbols

Electrical and electronic equipment symbols

	Indicates the device meets the requirements of the applicable EC directives.
	Indicates compliance with Part 15 of the FCC rules (Class A or Class B)
	Indicates the device is approved according to the TUV regulations for Canada and US
	Indicates the USB connectors on the device
	Indicates the Display Port connectors on the device
	Indicates the legal manufacturer
	Indicates the manufacturing date
	Indicates the temperature limitations for the device to safely operate within specs.
	Indicates the device serial number
	Indicates the device part number or catalog number
	Warning: dangerous voltage AVERTISSEMENT : Tension dangereuse
	Caution ATTENTION
	Consult the operating instructions

	Indicates this device must not be thrown in the trash but must be recycled, according to the European WEEE (Waste Electrical and Electronic Equipment) directive
	Indicates Direct Current (DC)
	Indicates Alternating Current (AC)
	Stand-by
	Power ON. Power connection to the mains
	Power OFF
	Protective earth (ground)
	Equipotentiality. Connect device to a potential equalization conductor.

Chapter 3 - Cleaning the display

► 3.1 Cleaning instructions

To clean the display

Cleaning the display using a sponge, cleaning cloth, or soft tissue with lightly moistened recognized cleaning product for medical equipment. Read and follow all labeled instructions on the cleaning product. In case of doubt about a certain cleaning product, use plain water.

CAUTION:

- Take care not to damage or scratch the front glass or LCD. Be careful with rings or other jewelry and do not apply excessive pressure on the front glass or LCD.
- Do not apply or spray liquid directly to the display as excess liquid may cause damage to internal electronics. Instead, apply the liquid to a cleaning sponge, cloth, or tissue.

ATTENTION :

- Veillez à ne pas endommager ou rayer la vitre avant ou l'écran LCD. Soyez prudent lorsque vous portez des bagues ou autres bijoux et n'appliquez pas une pression excessive sur le verre avant ou l'écran LCD.
- N'appliquez ou ne vaporisez pas de liquide directement sur l'écran car l'excès de liquide peut endommager l'électronique interne. Appliquez plutôt le liquide sur une éponge, un chiffon ou un mouchoir en papier.

► 3.2 EMC notice

Electromagnetic emissions

The monitor is intended for use in the electromagnetic environment specified below. The customer or the user of the monitor should assure that it is used in such an environment.

Emissions test	Compliance	Electromagnetic environment – Guidance
RF emissions CISPR 11	Group 1	The monitor uses RF energy only for its internal function. Therefore, its RF emissions are very low and are not likely to cause any interference with nearby electronic equipment.
RF emissions CISPR 11	Class B	
Harmonic emissions IEC 61000-3-2	N/A (power consumption less than 75W)	The monitor is suitable for use in all establishments, including domestic establishments and those directly connected to the public low-voltage power supply network that supplies buildings used for domestic purposes.
Voltage fluctuations/ flicker emissions IEC 61000-3-3	Complies	

This monitor complies with appropriate medical EMC standards on emissions to, and interference from surrounding equipment. Operation is subject to the following two conditions:

(1) this device may not cause harmful interference, and (2) this device must accept any interference received, including interference that may cause undesired operation. Interference can be determined by turning the equipment off and on.

If this equipment does cause harmful interference to, or suffer from harmful interference of, surrounding equipment, the user is encouraged to try to correct the interference by one or more of the following measures:

- Reorient or relocate the receiving antenna or equipment.
- Increase the separation between the equipment and receiver.
- Connect the equipment into an outlet on a circuit different from that to which the receiver is connected.
- Consult the dealer or an experienced technician for help.

Electromagnetic immunity

The monitor is intended for use in the electromagnetic environment specified below. The customer or the user of the monitor should assure that it is used in such an environment.

Immunity test	IEC 60601 Test levels	Compliance level	Electromagnetic environment – guidance
Electrostatic discharge (ESD) IEC 61000-4-2	± 8kV contact ± 15kV air	± 8kV contact ± 15kV air	Floors should be wood, concrete or ceramic tile. If floors are covered with synthetic material, the relative humidity should be at least 30%
Electrical fast transient/burst IEC 61000-4-4	± 2kV for power supply lines ± 1kV for input/ output lines	± 2kV for power supply lines ± 1kV for input/ output lines	Mains power quality should be that of a typical commercial or hospital environment
Surge IEC61000-4-5	± 1 kV line(s) to line(s) ± 2 kV line(s) to earth	± 1 kV line(s) to line(s) ± 2 kV line(s) to earth	Mains power quality should be that of a typical commercial or hospital environment
Voltage dips, short interruptions and voltage variations on power supply input lines IEC 61000-4-11	0% residual voltage for 0.5 cycle. 0% residual voltage for 1 cycle. 70% residual voltage for 0.5s. 0% residual voltage for 5s.	0% residual voltage for 0.5 cycle. 0% residual voltage for 1 cycle. 70% residual voltage for 0.5s. 0% residual voltage for 5s.	Mains power quality should be that of a typical commercial or hospital environment. If the user of the monitor requires continued operation during power mains interruptions, it is recommended that the monitor be powered from an uninterruptible power supply or a battery.
Power frequency (50/60 Hz) magnetic field IEC 61000-4-8	30 A/m	Not applicable	Power frequency magnetic fields should be at levels characteristic of a typical location in a typical commercial or hospital environment.

Conducted RF IEC 61000-4-6	3 V at 0,15 - 80MHz 6 V at ISM bands	3 V at 0,15 - 80MHz 6 V at ISM bands	Portable and mobile RF communications equipment should be used no closer to any part of the monitor, including cables, than the recommend separation distance calculated from the equation applicable to the frequency of the transmitter. Recommended separation distance $d = 1.2\sqrt{P}$ $d = 1.2\sqrt{P}$ 80 MHz to 800 MHz $d = 2.3\sqrt{P}$ 800 MHz to 2,5 Ghz Where P is the maximum output power rating of the transmitter in watts (W) according to the transmitter manufacturer and d is the recommended separation distance in meters (m). Field strengths from fixed RF transmitters, as determined by an electromagnetic site survey, ⁵ should be less than the compliance level in each frequency range. ⁶ Interference may occur in the vicinity of equipment marked with the symbol:
	10 V/m at 80-2,700MHz. And 9-28V/m at 385-6,000MHz, Pulse Mode: 27 V/m at 385MHz 28 V/m at 450MHz 9V/m at 710/745/780MHz 28 V/m at 810/870/930MHz 28 V/m at 1720/1845/1970MHz 28 V/m at 2450MHz 9V/m at 5240/5500/5785MHz		
Radiated RF IEC 61000-4-3	10V/m at 80-2,700MHz. And 9-28V/m at 385-6,000MHz, Pulse Mode: 27 V/m at 385MHz 28 V/m at 450MHz 9V/m at 710/745/780MHz 28 V/m at 810/870/930MHz 28 V/m at 1720/1845/1970MHz 28 V/m at 2450MHz 9V/m at 5240/5500/5785MHz		

Note:
At 80 MHz and 800 MHz, the higher frequency range applies.

These guidelines may not apply in all situations. Electromagnetic propagation is affected by absorption and reflection from structures, objects, and people.



Chapter 4 - Monitor Installation



Warning: Sufficient expertise is required to install this equipment. All devices and complete setup must be tested before operation.



AVERTISSEMENT: Une expertise suffisante est requise pour l'installation de cet équipement. Tous les appareils et la configuration complète doivent être testés avant d'être mis en service.

► 4.1 Cleaning instructions

To install your monitor

- To get access to the connectors, put the display on a flat surface.
1. Connect one or more video source(s) to the corresponding video inputs of the monitor. Use the appropriate video cable(s) to do this.
 2. Connect the USB or RS232 connector for touch screen function.
 3. Connect the Audio cable for audio function.
 4. Connect the power cord input to a power adapter with a grounded Power Outlet.
 5. Connect the power adapter input to the monitor.
 6. Install cable cover back on the monitor.

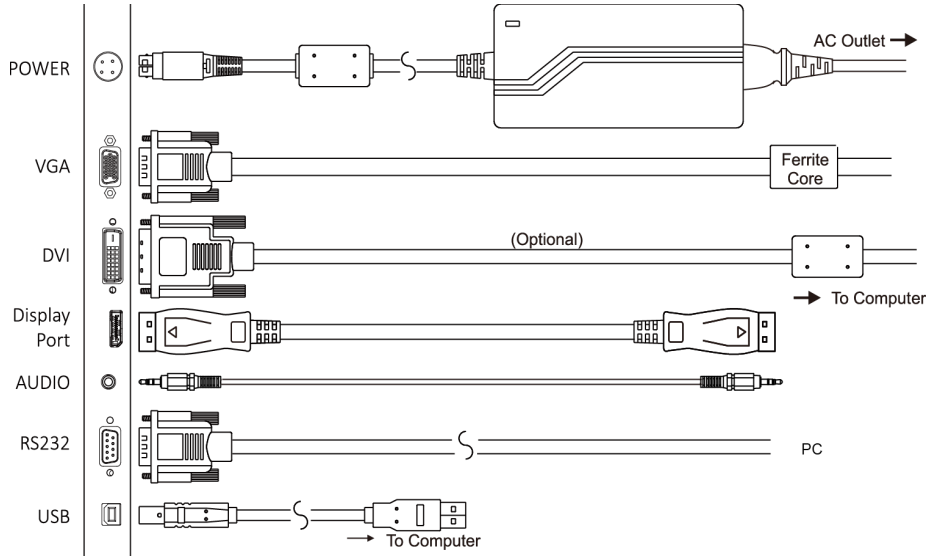

Image 4-1-1 Connectors (RGP)

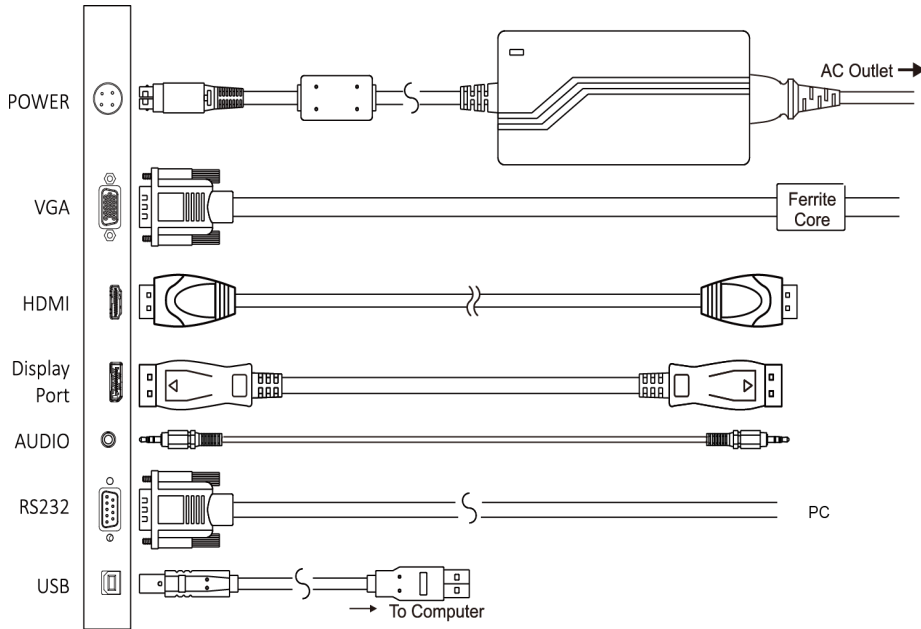

Image 4-1-2 Connectors (RGD)

► 4.2 Stand removal & VESA mount installation

This monitor provided with a validated stand. The monitor has been designed to be used in landscape position with a maximum tilt of -5° to 30° backward. If a different stand is needed in the final application, the monitor VESA interface (VESA 100 mm standard) could be used.

To remove the stand and install the VESA mount

1. Place the monitor face down on a flat, solid and stable surface.
2. Remove the hinge cover
3. Unscrew the 4x M4 (length: 10mm) screws fixing the stand and rear cover
4. Remove the stand and install the VESA mount.

Caution: Use a protective cloth or cushion to prevent the monitor and LCD from any damage or scratches.

Attention: Utilisez un chiffon ou un coussin de protection pour éviter d'endommager ou rayer le moniteur et l'écran LCD.

Tip: Store the fixation screws at a known place for possible future use.

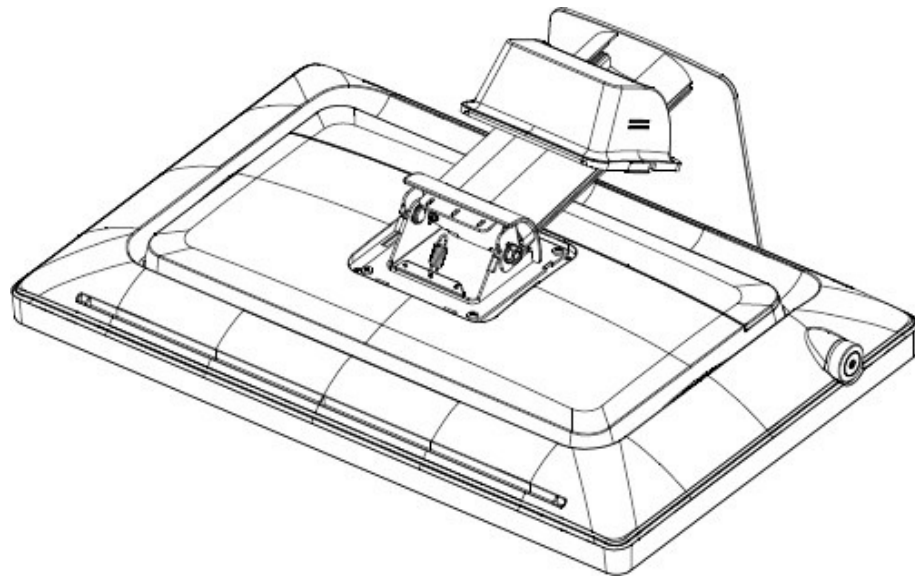

Image 4-2-1 Remove the hinge cover

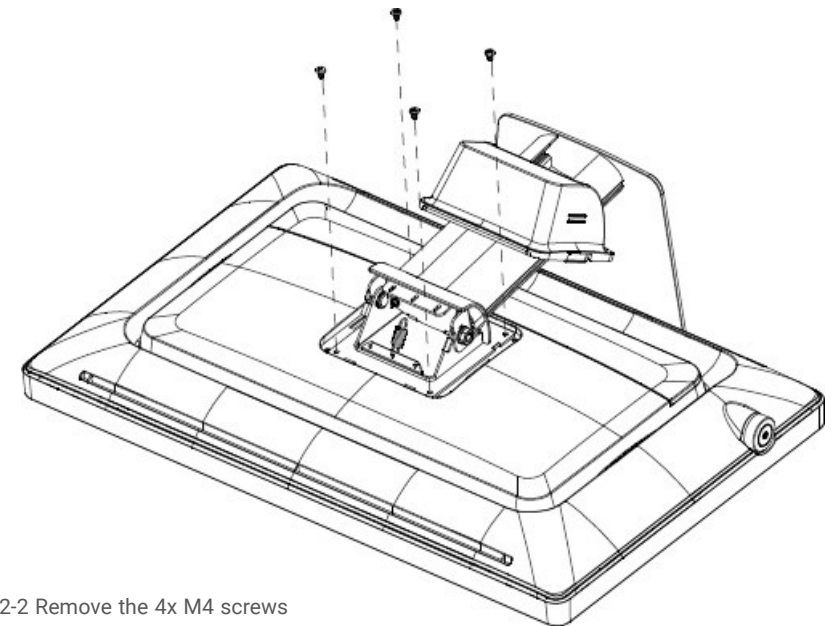

Image 4-2-2 Remove the 4x M4 screws

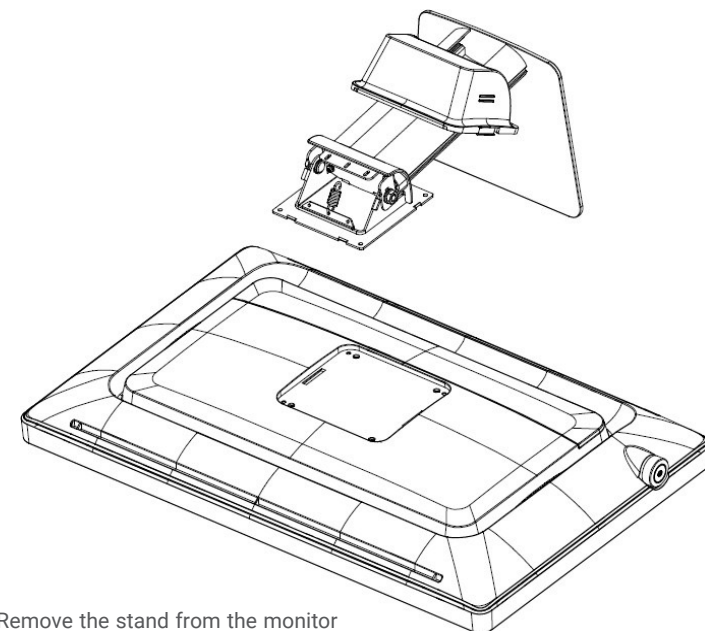

Image 4-2-3 Remove the stand from the monitor

5. Attach the monitor in landscape position to a 100 mm VESA mounting bracket. Mounting in portrait position is not feasible.

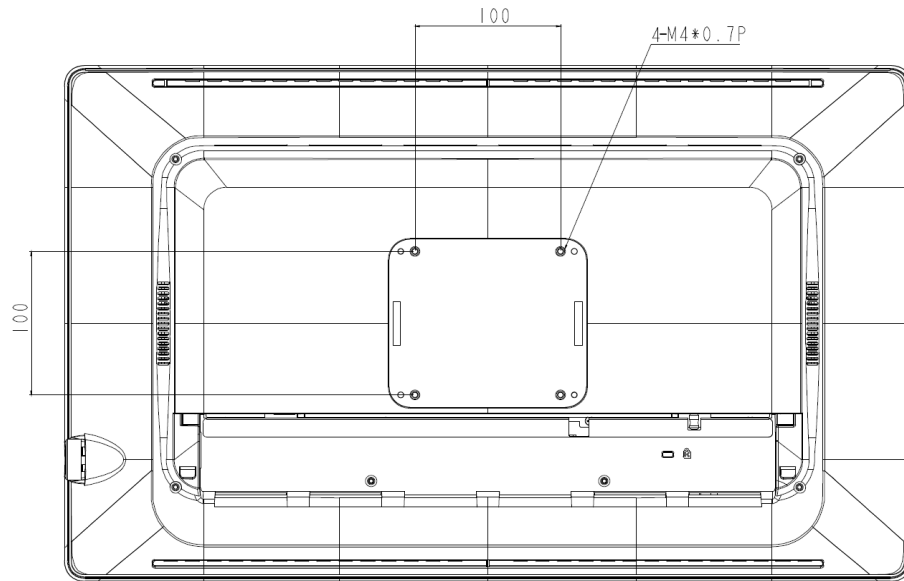

Image 4-2-4 VESA mount is located at the back of the monitor.

Chapter 5 - Daily operation

► 5.1 Main power switch

The monitor is switched on or off with the main switch, **sees image 1-2 Control key**.

► 5.2 Power/Status indication

During start-up the monitor performs signal detection before going into normal operation mode. Depending on the detection result, the status LED on the side of the monitor will show different LED color.

Below is an overview of the possible status LED modes:

LED Color	Status LED modes	Operation Description
OFF (No LED)	OFF mode	Monitor is not powered.
Blue, static	Normal mode	Monitor is ON, video sync OK.
Red, static	Stand-by mode (Power saving)	Automatically enters power saving and standing by for input signal

Chapter 6 - OSD menu operation

The Charts displays the function tree and brief explanations of the functions. Color, OSD, and other adjustments have submenus under each tree.

► 6.1 On-Screen Display

The LCD monitor features an On-Screen Display (OSD) menu with easily identifiable icons designed to make adjustment of your monitor display settings a more user-friendly process. When highlighted, the icon illustrates the control function and brief instruction to assist the user in identifying which control needs adjustment.

The OSD menu is activated by pressing the Control Dial inward and you can select and adjust the function of your choice by rotating and clicking the Control Dial. The main menu displays a list of sub menu icons and the current video input mode. Rotate the dial to move the highlights to the control you would like to adjust, then press the Control Dial inward to select that control or to activate that function. Depending on the control you selected, a submenu of the control with a status bar will appear. The status bar indicates in which direction, from the factory preset; your adjustments are being made. Rotate the Control Dial to adjust the control.

When you have finished making the adjustments, the setting is saved automatically by activating the control function. If you do not touch the Control Dial for 30 seconds, the OSD is automatically exited saving your current settings.

► 6.2 Menu Descriptions

The LCD monitor is capable of accepting VGA, DVI(HDMI), Display Port signal inputs and therefore has two different sets of OSD control functions. Because the digital signaling always achieves optimum display quality without much adjustment, it requires much less OSD functions than the analog input mode. The following options are not available in digital input mode: Auto Setup, Display, Clock/Phase, denoted by as trick (*) in the following descriptions. If switched to digital input model, you will encounter a "Not Available" message.

► 6.3 OSD Structure

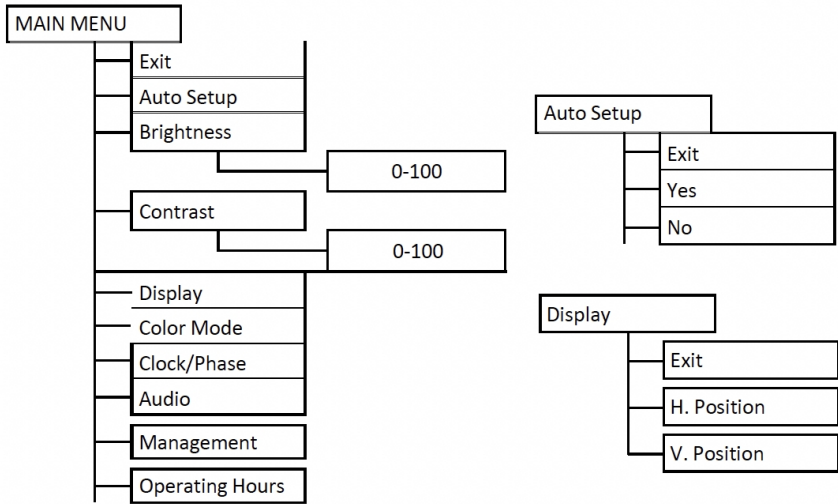

► 6.4 Main Menu

6.4.1 Exit

To exit the OSD menu.

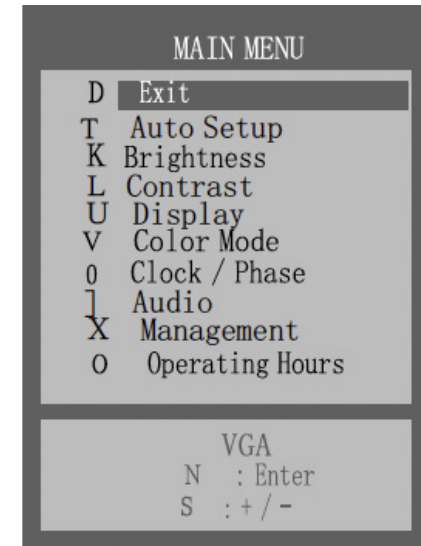
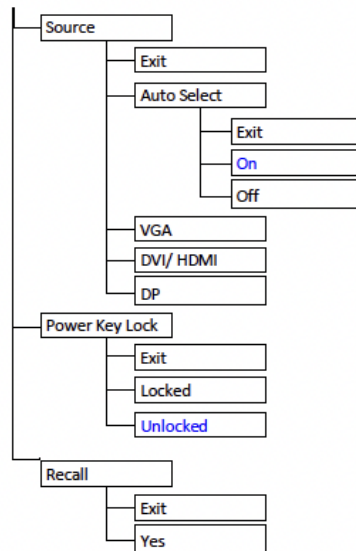
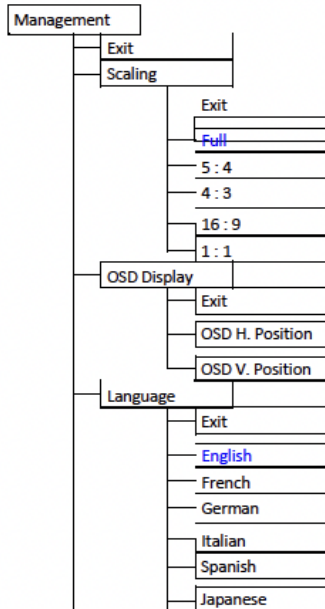
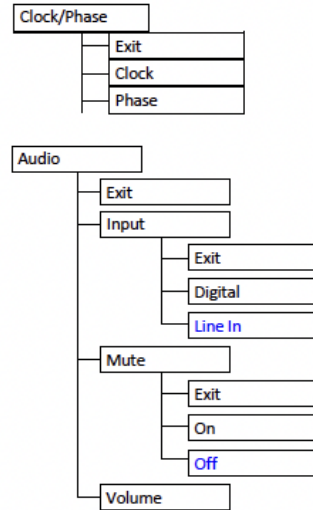
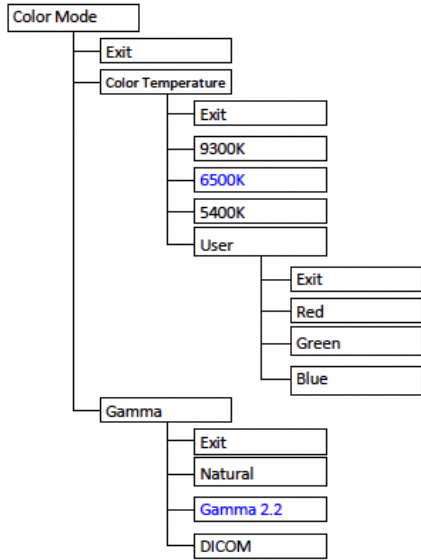

Image 6-4 Main OSD menu



6.4.2 Auto Setup (Only Support Analog)

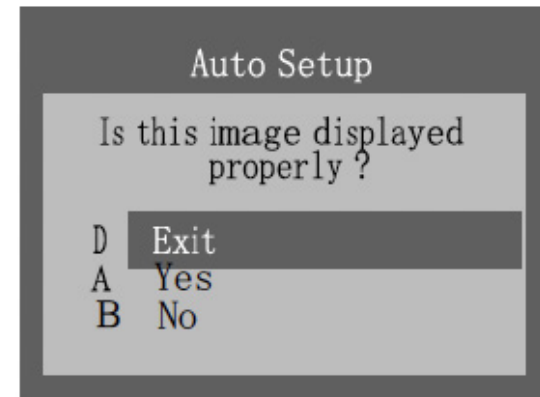

Image 6-4-2 Auto Setup OSD menu

- Exit: To exit the auto setup of the OSD menu.
- Yes: Automatically adjust the analog settings of the image.
- No: Enter Clock/Phase OSD menu when NO is selected.

6.4.3 Brightness

This function allows the user to adjust the monitor's brightness setting manually.

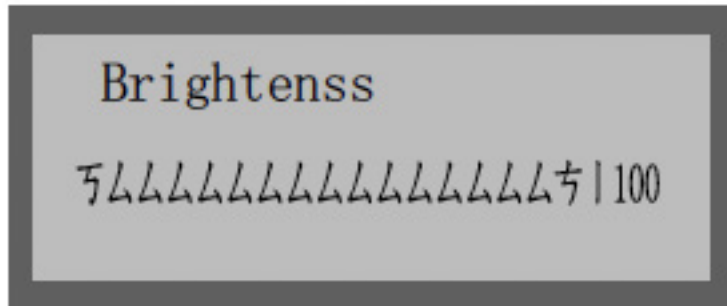

Image 6-4-3 Brightness OSD menu

6.4.5 Display (Only Support Analog)

• Exit: To exit the display of the OSD menu.

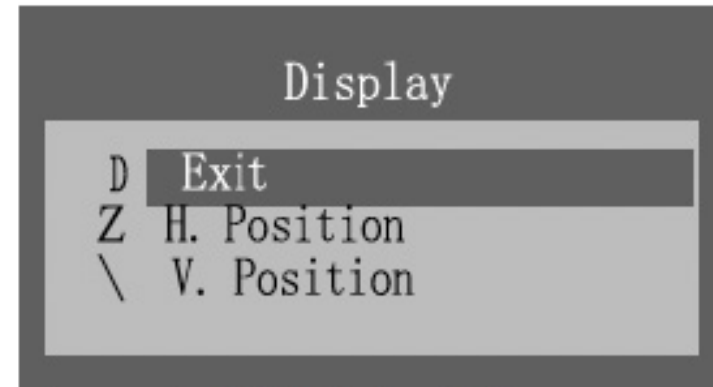

Image 6-4-5-1 Display OSD menu

6.4.4 Contrast

This function allows the user to adjust the contrast setting of the monitor manually.

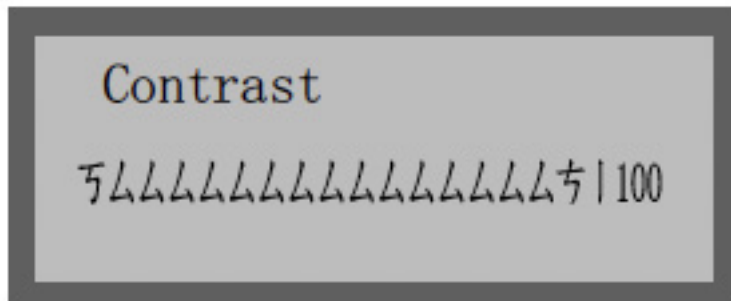

Image 6-4-4 Contrast OSD menu

• H. Position: The function allows user manually adjust the image position horizontally on the screen.

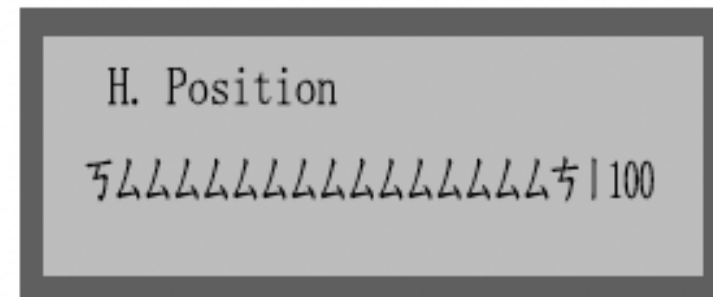

Image 6-4-5-2 H. Position OSD menu

OSD menu operation

- V. Position: The function allows users manually adjust the image position vertically on the screen.

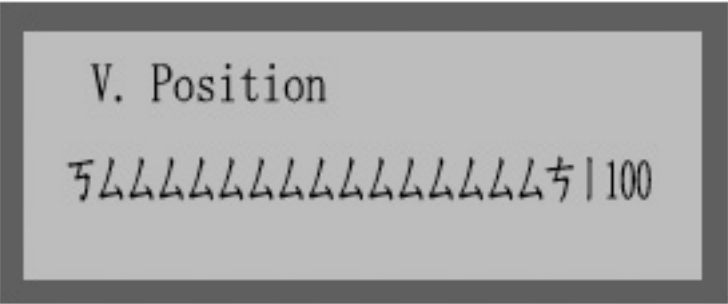

Image 6-4-5-3 V. Position OSD menu

- Color Temperature: Allows users to select preset color temperature of the display setting. Preset color temperatures are 9300K, 6500K, 5400K & User adjustable color temperature.

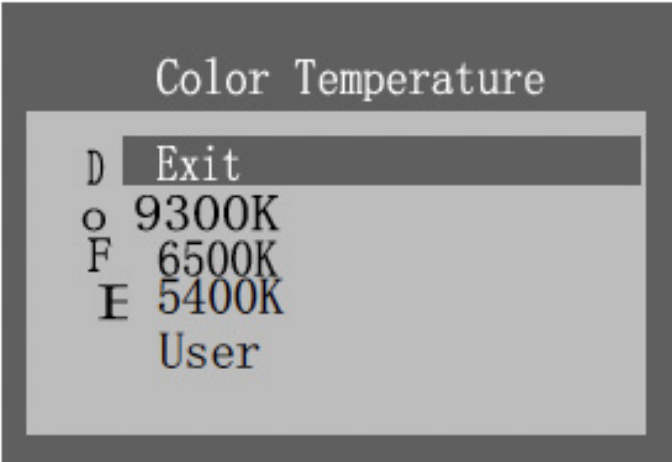

Image 6-4-6-1 Color Temperature OSD menu

6.4.6 Color Mode

- Exit: To exit the color mode of the OSD menu.

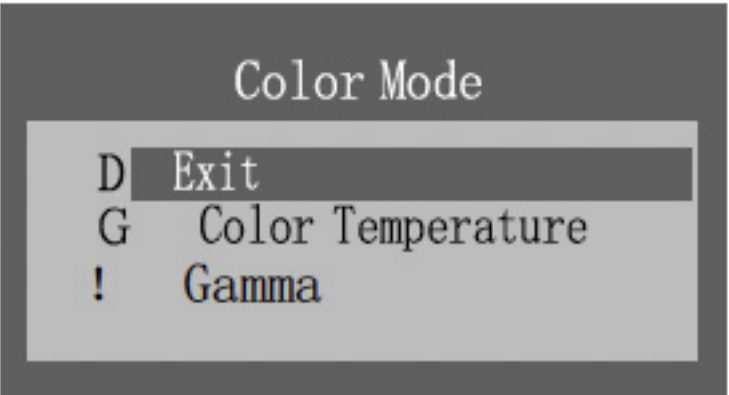

Image 6-4-6 Color Mode OSD menu

- User: User can adjust and set tones.

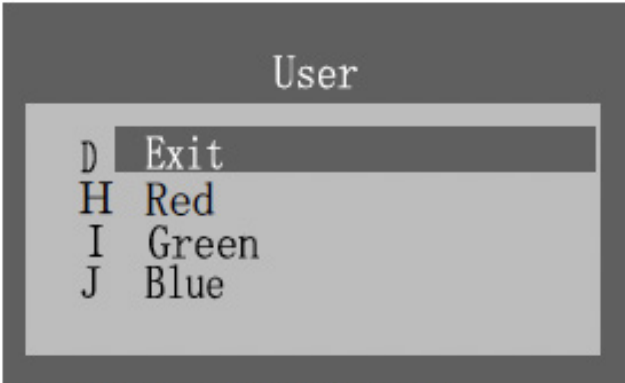

Image 6-4-6-2 User OSD menu

- Red: Adjust red and equivalent colors at the range from 0 to 100. The greater the value is, the deeper the color is, and vice versa.
 - Yes: Automatically adjust the analog settings of the image.
 - Green: Adjust green and equivalent colors at the range from 0 to 100. The greater the value is, the deeper the color is, and vice versa.
 - Blue: Adjust blue and equivalent colors at the range from 0 to 100. The greater the value is, the deeper the color is, and vice versa
- User can adjust and set tones.

- Gamma: Allows users to select preset gamma curve of the display setting. Preset gamma curve are Neutral & Gamma 2.2.
- DICOM: Allows users to select preset DICOM curve of the display setting.

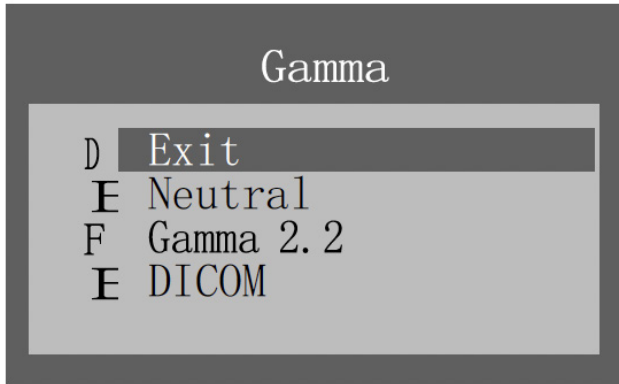
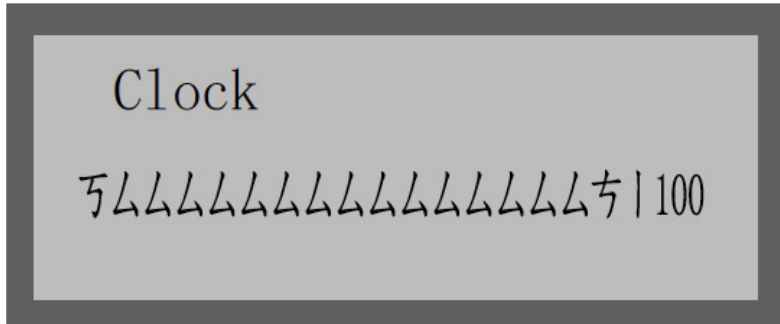

Image 6-4-6-3 Gamma OSD menu

6.4.7 Clock/Phase (Only support Analog)

- Exit: To exit the Clock / Phase of the OSD menu.
- Clock: Allows users to adjust the clock of the display setting manually



- Phase: Allows users to adjust the phase of the display setting manually.

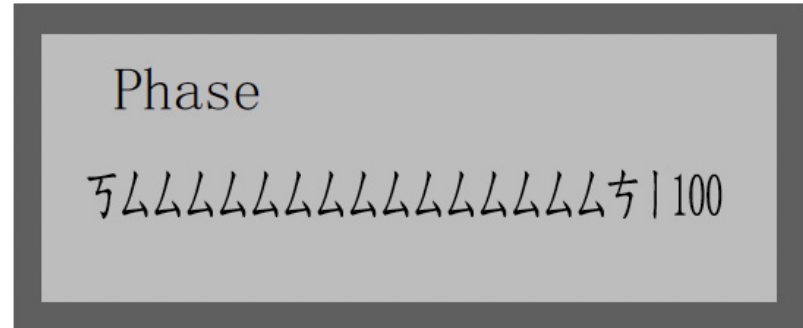

Image 6-4-7-2 Phase OSD men

6.4.8 Audio

- Exit: To exit the Audio of the OSD menu.

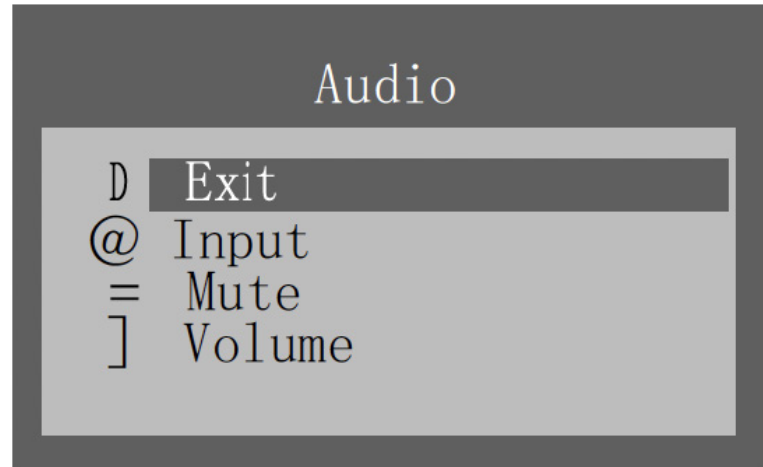

Image 6-4-8 Audio OSD menu

- Input: Allows users to select the audio input source of the display setting. Digital & Line-In audio input source are available.

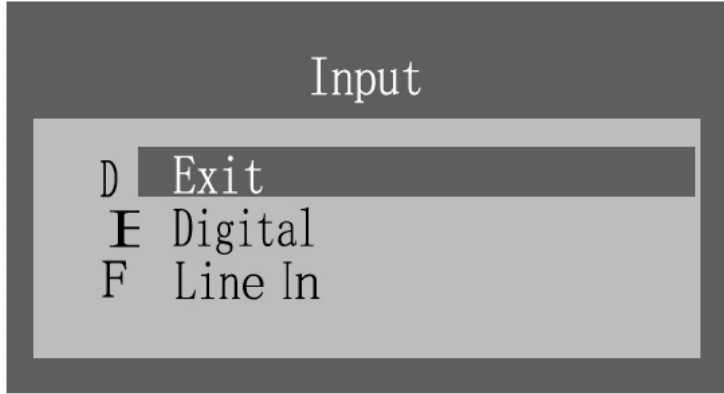

Image 6-4-8-1 Audio Input OSD menu

- Mute: Allows users to Mute(On) & Unmute(Off) the audio output of the display setting.

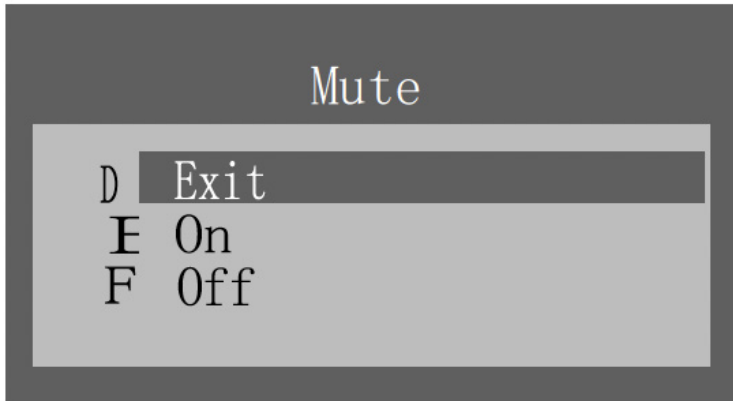

Image 6-4-8-2 Audio Mute OSD menu

- Volume: Allows users to adjust the audio output of the display setting.

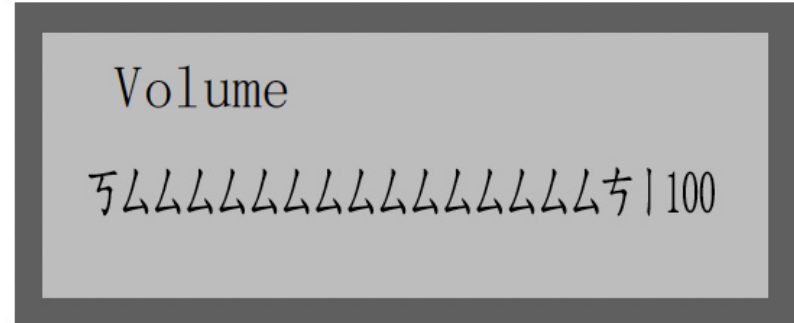

Image 6-4-8-3 Audio Volume OSD menu

6.4.9 Management

- Exit: To exit the Management of the OSD menu.

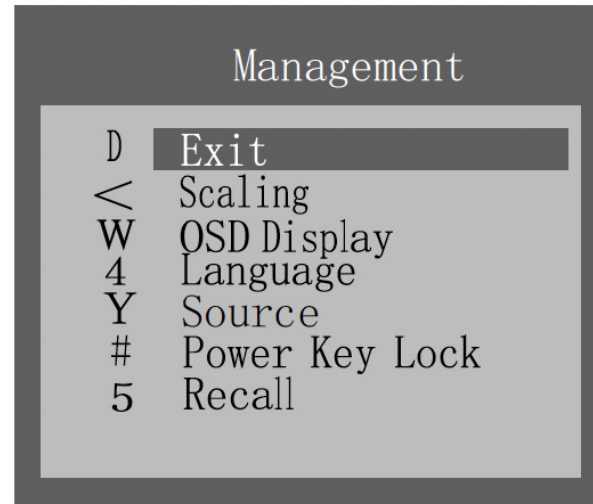

Image 6-4-9 Management OSD menu

6.4.9.1 Scaling

- Allows users to select preferred image scaling of the display setting.
- Full screen: Expands the current image to the full size of the monitor.
- Aspect ratio (5:4, 4:3, 16:9): Expands the video image until its largest dimension fills the screen, while maintaining the aspect ratio of the image size. For example, when input timing is not equal to panel native resolution 1920x1080 (16:9 aspect ratio), the image may be displayed with black bars to fill the screen.
- 1 : 1: Display image as its original input image resolution.

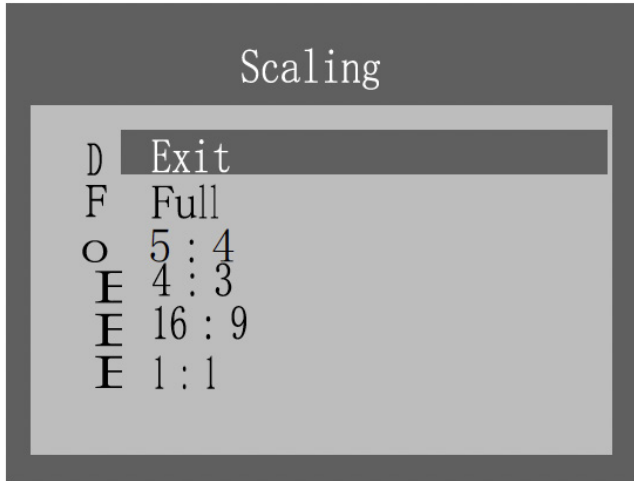

Image 6-4-9-1 Scaling OSD menu

6.4.9.2 OSD Display

- Exit: To exit the OSD Display of the OSD menu.

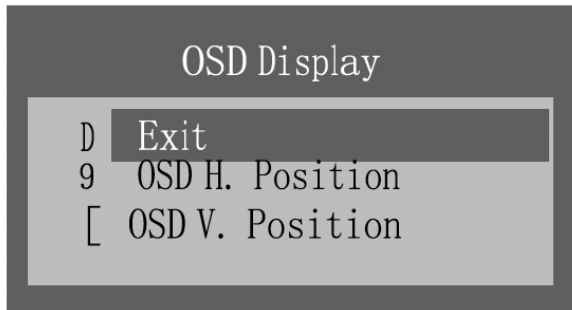

Image 6-4-9-2 OSD Display menu

- OSD H. Position: Allows users to set OSD menu in horizontal position on the display.

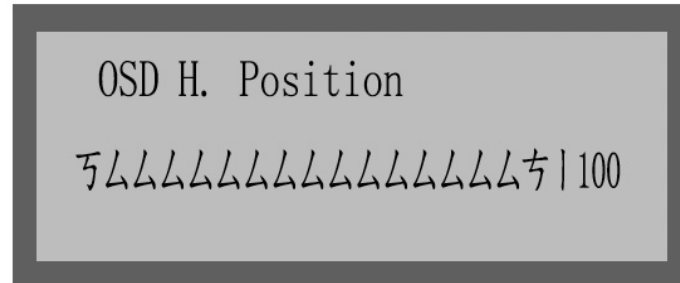

Image 6-4-9-2a OSD Horizontal Position OSD menu

- OSD V. Position: Allows users to set OSD menu in vertical position on the display.

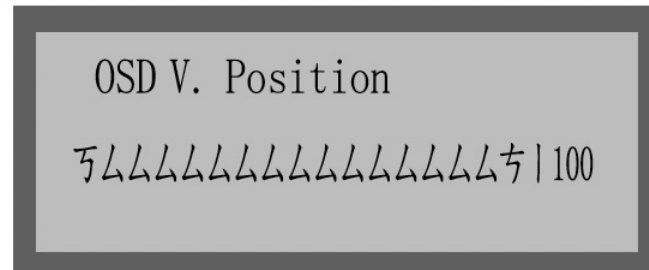

Image 6-4-9-2b OSD Vertical Position OSD menu

6.4.9.3 Scaling

- Exit: To exit the Language of the OSD menu.
- English, French, German, Italian, Spanish & Japanese OSD menu languages are available for users to select preferred languages.

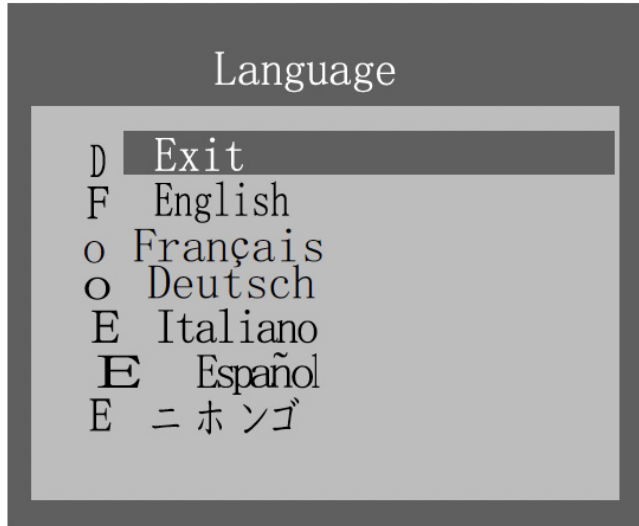

Image 6-4-9-3 Language OSD menu

6.4.9.4 Source

- Exit: To exit the OSD Display of the OSD menu.

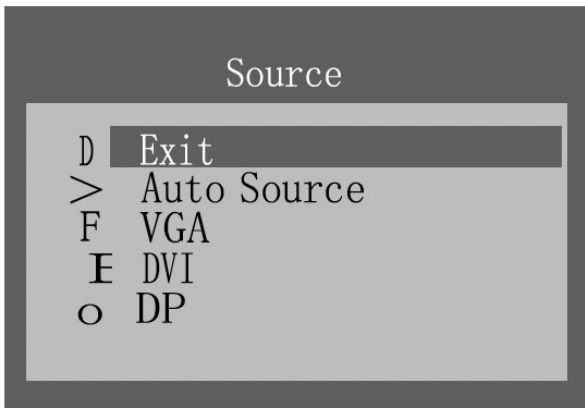

Image 6-4-9-4a Source OSD menu (RGP)

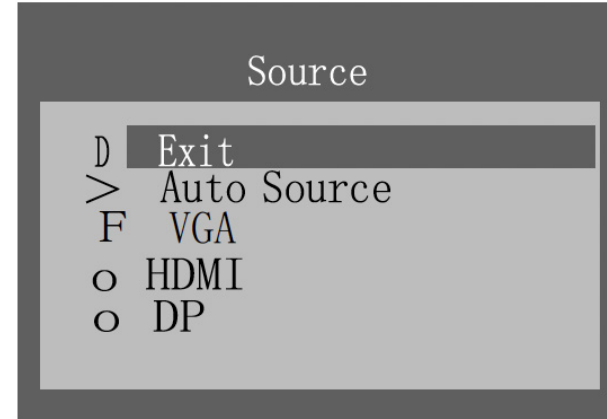

Image 6-4-9-4b Source OSD menu (RGD)

- Exit: To exit the Source of the OSD menu.
- Auto Source: Allows users to Enable or Disable the Auto Select function of the display setting.

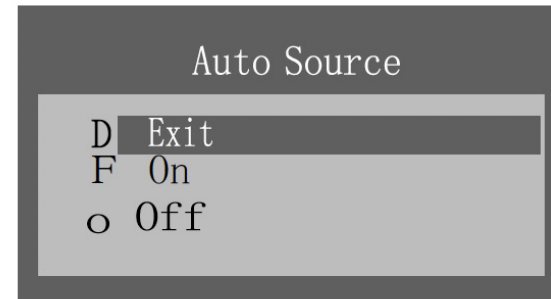

Image 6-4-9-4 Auto Source of the Source OSD menu

- VGA, DVI & Display Port (DP)/ HDMI sources are available for user to select preferred input source.

6.4.9.5 Power Key Lock

- Exit: To exit the Power Key Lock of the OSD menu.
- Locked: Allows users to Enable the DC power key function of the display setting.
- Unlocked: Allows users to Disable the DC power key function of the display setting.

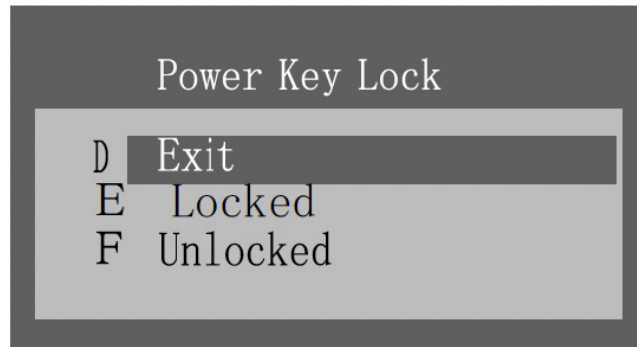

Image 6-4-9-5 Power Key Lock OSD menu

6.4.9.6 Recall

- Exit: To exit the Recall function of the OSD menu.
- Yes: Allows users to recall the display setting back to factory default setting.

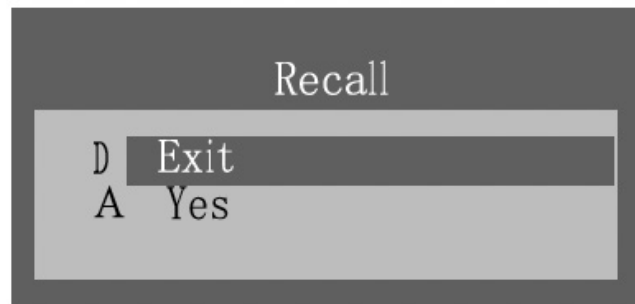

Image 6-4-9-6 Recall OSD menu

6.4.10 Operating Hours

- Keep records of the monitor operating hours.

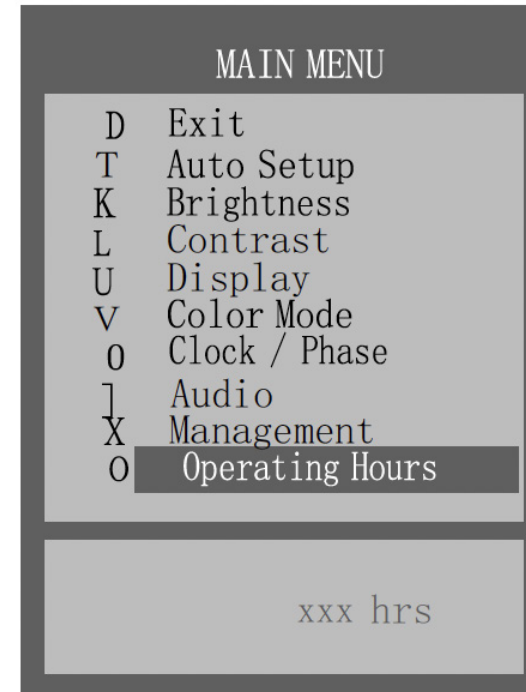

Image 6-4-10 Operation Hours OSD menu

6.5 Supported Video Modes

• Compliant Graphic Signal Timing (VGA, DVI, HDMI & DP)

Resolution	Pixel-rate [MHz]	Line-rate [kHz]	Frame-rate[Hz]	VGA	DVI/ HDMI	DP
640x480	25.200	31.500	60.000	0	0	0
640x480	31.500	37.861	72.809	0		
640x480	31.500	37.500	75.000	0		
720x400	28.322	31.469	70.087	0	0	0
800x600	36.000	35.156	56.250	0		
800x600	40.000	37.879	60.317	0	0	0
800x600	50.000	48.077	72.188	0		
800x600	49.500	46.875	75.000	0		
1024x768	65.000	48.363	60.004	0	0	0
1024x768	75.000	56.476	70.069	0		
1024x768	78.750	60.023	75.029	0		
1280x1024	108.000	63.981	60.020	0	0	0
1280x1024	135.000	79.976	75.025	0		
1600x1200	162.000	75.000	60.000	0	0	0
1920x1080	148.504	67.502	60.002	⊙	⊙	⊙